



**COMMISSIONERS COURT  
COMMUNICATION**

COURT ORDER NUMBER 145147

PAGE 1 OF 3

DATE: 5/6/2025

**SUBJECT: CONSIDERATION OF A BUILDING RENOVATION OF ROOM 460  
LOCATED ON THE 4TH FLOOR OF THE 1895 COURTHOUSE FOR THE  
PRECINCT 1 CONSTABLE'S OFFICE**

**\*\*\* CONSENT AGENDA \*\*\***

**COMMISSIONERS COURT ACTION REQUESTED**

It is requested that the Commissioners Court consider a building renovation of Room 460, located on the 4th floor of the 1895 Courthouse, for the Precinct 1 Constable's Office.

**BACKGROUND**

In the approved FY 2025 budget, the Commissioners Court allocated \$25,000.00 for the renovation of Room 460 on the 4th floor of the 1895 Courthouse for the Precinct 1 Constable's Office.

The renovation includes two (2) new workstations with a transaction top and passthrough glass reception desk. This addresses the need for staff to face the main entrance as a safety measure. The project includes the construction of a new transaction counter to match existing millwork as well as relocation of existing electrical and data systems to accommodate the new design.

The renovation will consist of millwork, electrical, and data improvements.

**FISCAL IMPACT**

Funding in the amount of \$10,706.00 is available in account 45100-2025 Non-Debt Capital Fund/3110403000 1895 Courthouse/540000 Capital and is within the previously approved budget.

SUBMITTED BY	Facilities Management	PREPARED BY:	Milissa Warner
		APPROVED BY:	Frank Lopez

## 1895 OCH Pct 1 Millwork

Budget Estimate date 3/5/25

The budget below is based from the following scope of work:

1. This budget includes a total of 18 Linear Feet of Transaction Counter at the 1895 Courthouse
2. This budget does not include relocation costs.
3. This budget does not include operating costs.
4. This budget does not include furnishings.

### Capital Budget Summary

1. SITE WORK	\$	-
2. DEMOLITION / ABATEMENT	\$	180.00
3. CONSTRUCTION COST OF THE BUILDING	\$	10,015.63
General Requirements	\$	-
Concrete	\$	-
Gypsum Board Assemblies	\$	314.93
Openings	\$	1,650.00
Finishes	\$	5,683.50
Elevator	\$	-
Mechanical Systems	\$	-
Electrical Systems	\$	2,367.20
Plumbing Systems	\$	-
Special Equipment	\$	-
Low Voltage	\$	-
General Contractor (1 if bid out, 0 if performed in-house)	\$	-
4. PROFESSIONAL SERVICES	\$	-
Pre-design (programming, preliminary drawings, site alternates)	\$	-
Full Architect / Engineering Services (triggered if HC is > \$50,000)	\$	-
Lab Design Consultant	\$	-
Geotechnical Survey	\$	-
Phase 1 / 2 Asbestos Surveys	\$	-
Inspections / Testing	\$	-
HVAC - Test and Balance	\$	-
Commissioning - LEED	\$	-
Document Reproduction	\$	-
5. PERMITS & FEES	\$	-
6. OCCUPANCY EXPENSES	\$	-
7. OWNER'S CONTINGENCY	\$	509.78
Tarrant County Facilities Management		
<b>TOTAL PROJECT BUDGET : If Self-Perfomed</b>	<b>\$</b>	<b>10,705.41</b>

All millwork fabrication and installation performed by Tarrant County FMCS Personnel

**Cost of Self-Performed Tradesmen** **\$** -

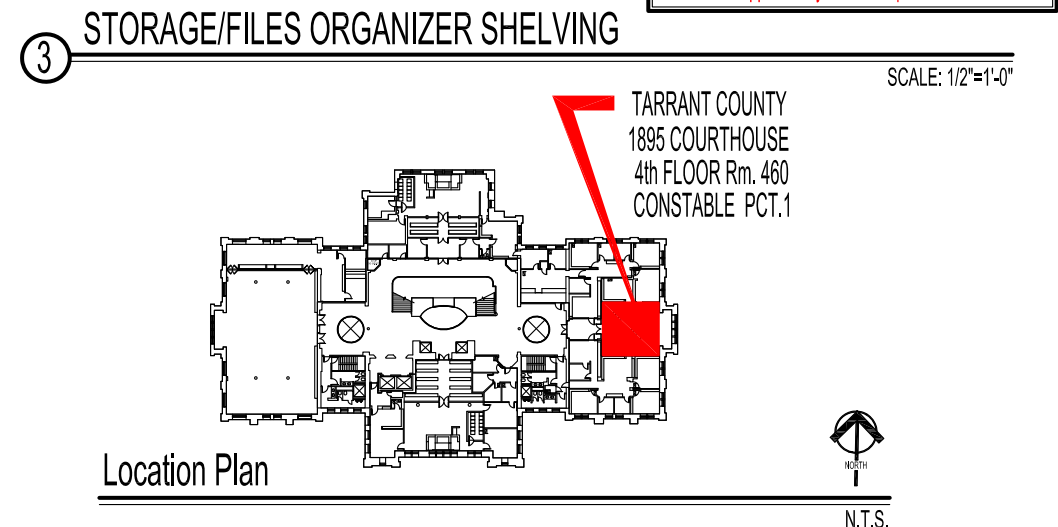
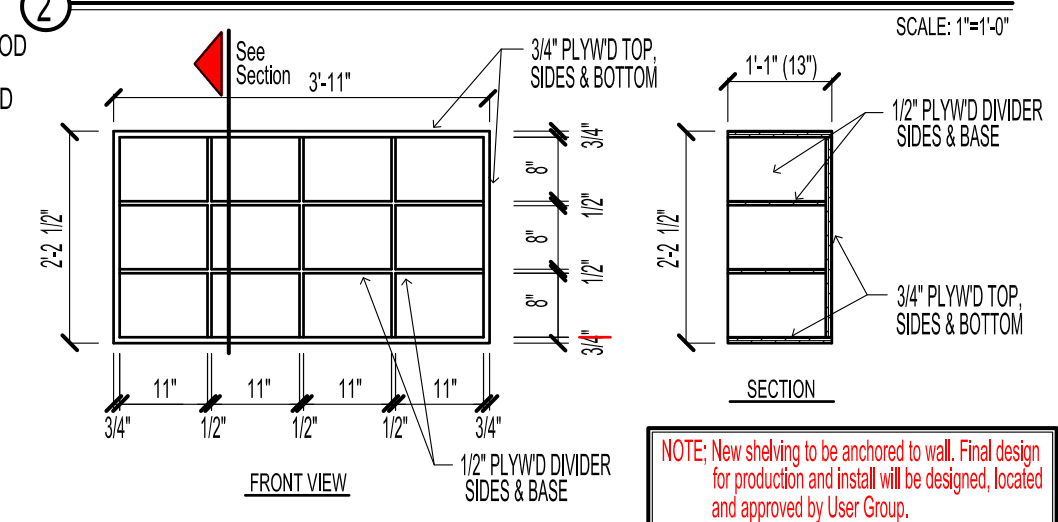
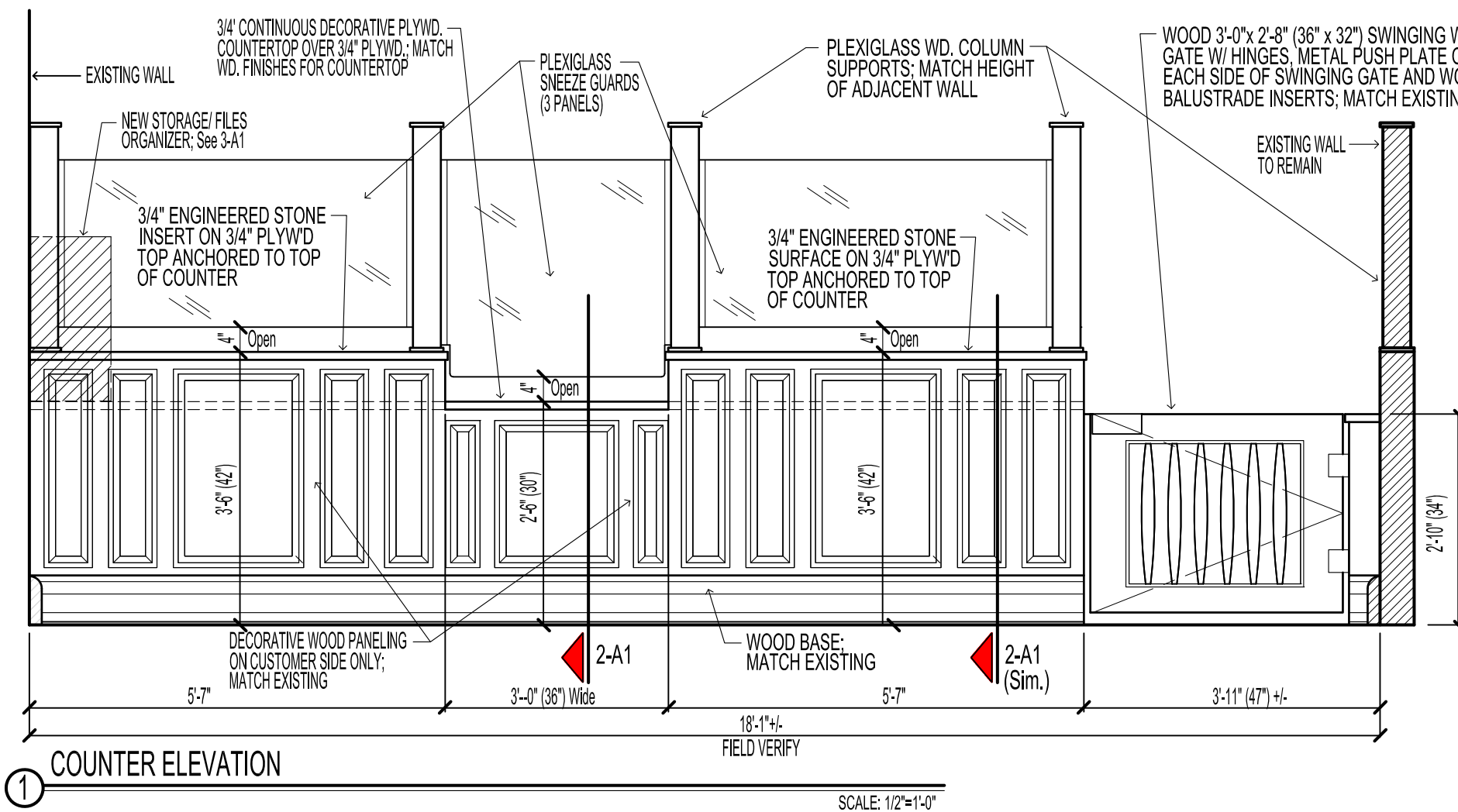
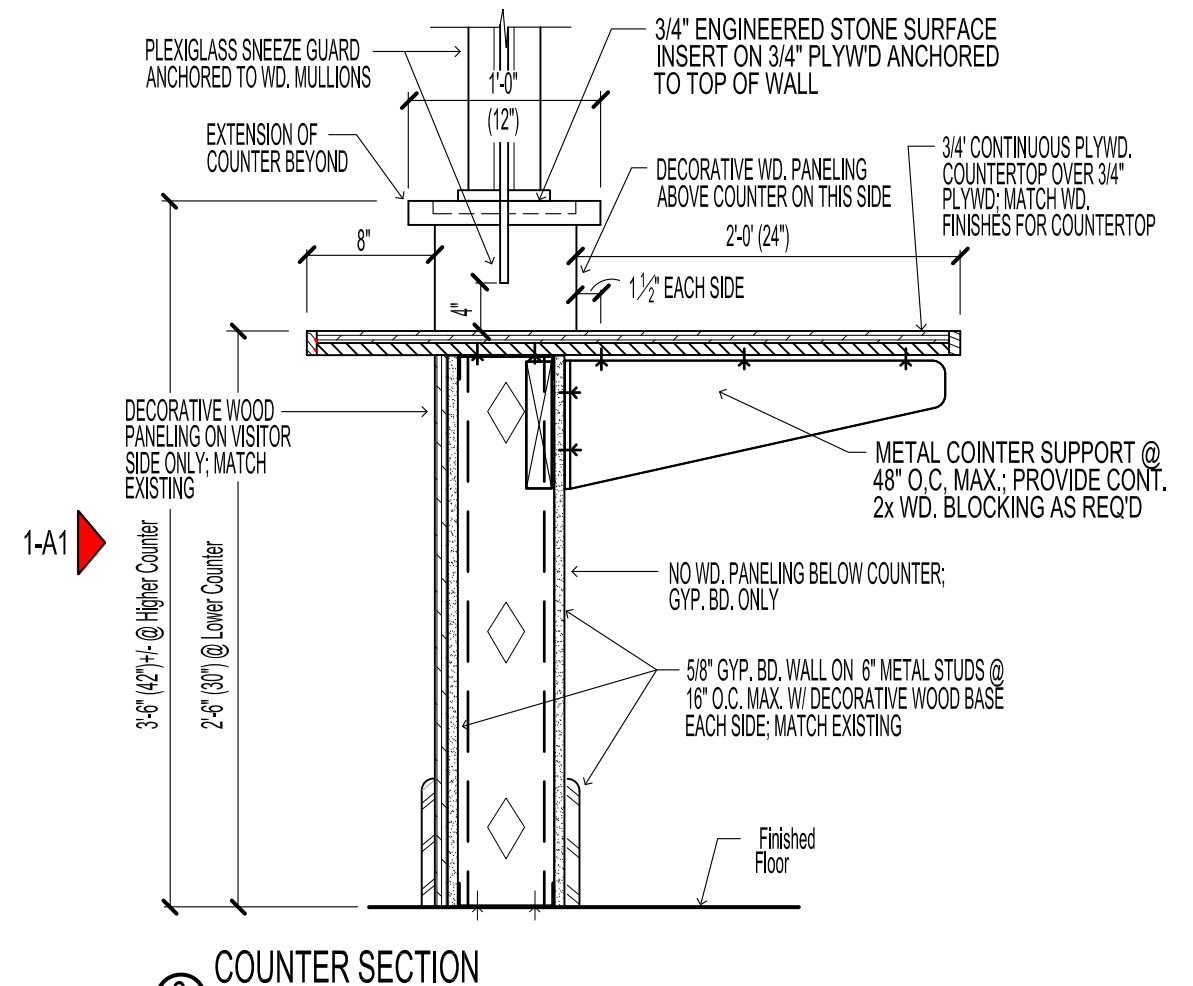
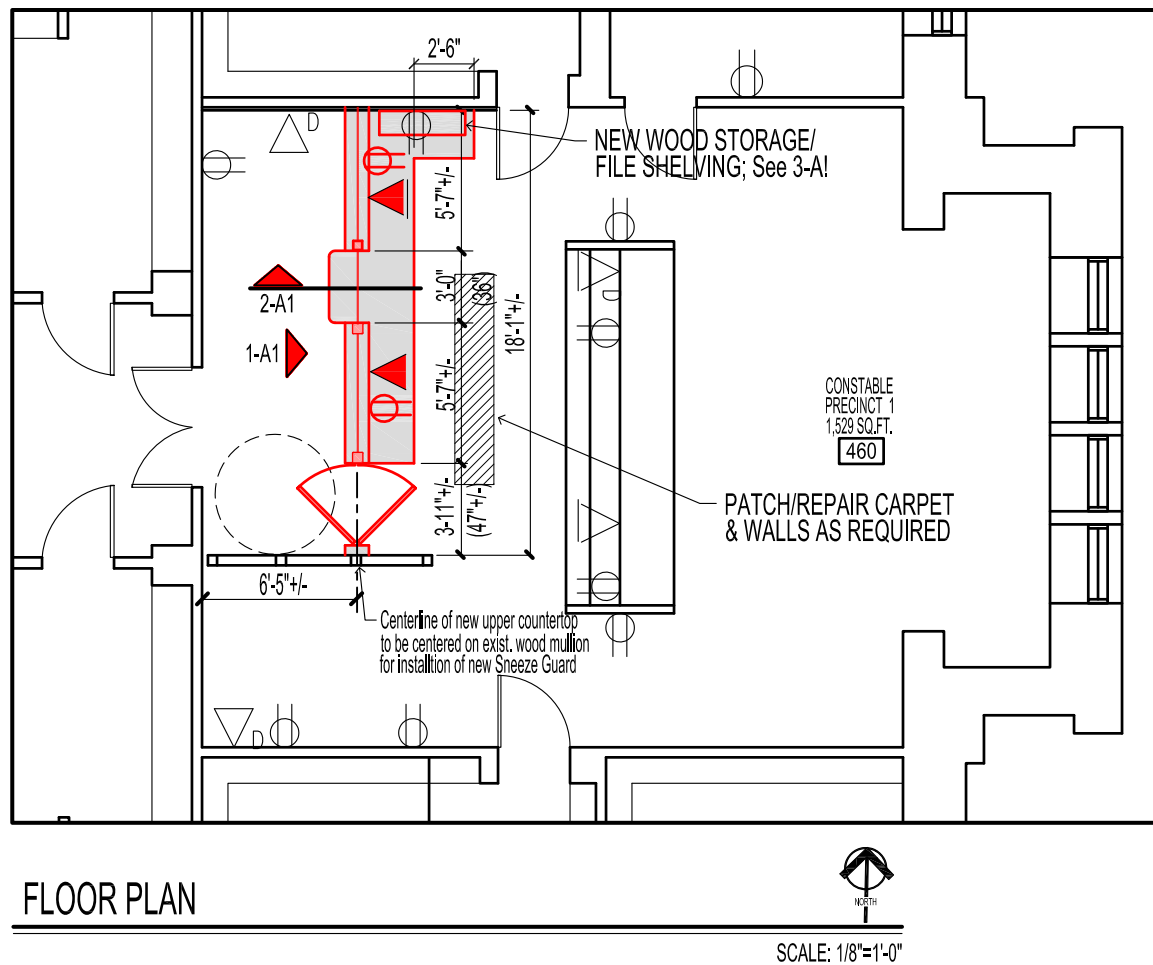
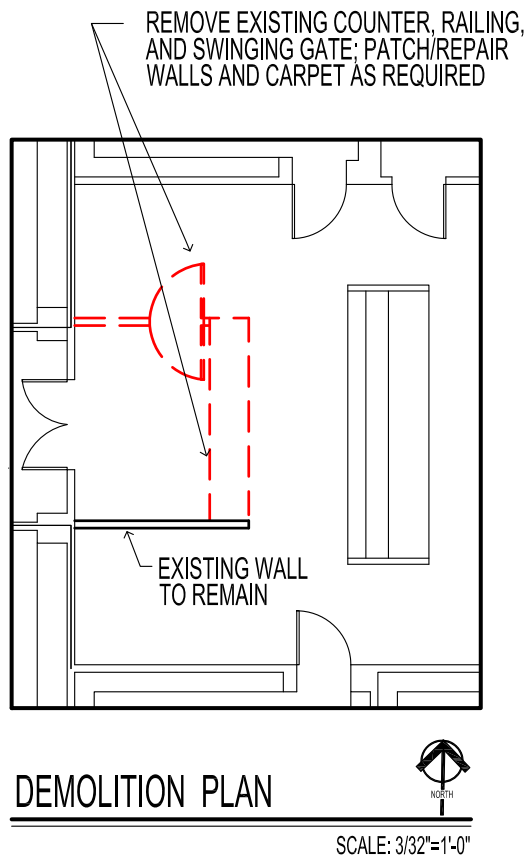

Tarrant County - Facilities Management  
Construction Services  
100 W. Weatherford St., Room 350  
Fort Worth, Texas 76196  
p: (817) 884-1502

RECEPTION COUNTER FOR CONSTABLE PCT. 1  
1895 COURTHOUSE 4TH FLOOR RM. 460  
FLOOR PLAN, COUNTER ELEVATION, COUNTER SECTION, LOCATION PLAN

DRAWING NUMBER  
OCH Const. Pct 1 4th Flr Rm 460  
DATE: January 9, 2025  
DRAWN BY: H.C.  
SHEET NO.  
**A-1**  
1 OF 1 SHEETS